

# DESIGN OF FUZZY-PD CONTROLLER FOR HEATING SYSTEM TEMPERATURE CONTROL

Intisar N. Al-Obaidi<sup>1\*</sup> , Abbas H. Issa<sup>2</sup>

<sup>1</sup>Computer Techniques Engineering Dept., Bilad Al-Rafidain University College

<sup>2</sup>Department of Electrical Engineering, University of Technology-Baghdad

[abbas\\_hissa@yahoo.com](mailto:abbas_hissa@yahoo.com)

## Abstract

The temperature control of medical and biological ovens required a high precision controller. A Fuzzy-PD (Fuzzy-Proportional Derivative) controller is designed in this research for controlling the temperature of the heating system. The controlled heating system is a small laboratory oven used for biological experiments. The controller is designed using MATLAB version 7.14 program. SIMULINK environment of MATLAB program is used in designing the controller. The output response of the complete heating system for unit step input is obtained. The inputs and output membership function (MF) and also the surface viewer for the Fuzzy-PD controller are presented in this research. The simulation results show the good performance of the designed controller and its suitability and adaptability for such sensitive application.

**Keywords:** Modeling, biomedical oven, PID, FLC, Fuzzy-PD

**Article history:** Received 6 January 2022 , Accepted 27 February 2022

This article is open-access under the CC BY 4.0 license (<http://creativecommons.org/licenses/by/4.0/>).

## 1. Introduction

The temperatures control the sensitivities of biology and a medical application is vital particularly when the temperature is a quintessential condition. That's control in conformity with the care because right then environment friendly controller according to meet scientific requirements, then so execute remain found of synthetic artificial intelligent technique [1].

Artificially controlled structures have a wide spread of engineering capabilities in practice, where controllers are the best stable robustness among explaining a number of phenomena as in many biomedical or organic systems [2]. Various strategies have been applied to zeal dictation controls, such as PID, NN, FLC, etc. They are also widely used in controlling temperature regimes [3].

For a long time and the researchers trying to find the best strategies to control the temperature of heating systems, starting from the traditional controllers who's the best and robust one of them is the PID controller, and go far to the intelligent controllers which brings the researchers attention for its adaptability and reliability that now a day's become the more powerful and adaptable techniques [4].

A Fuzzy controller for the elimination of the deviation in temperature and humidity in an air impingement lab oven was presented [5]. The lab oven used for the reduction of pathogens like Salmonella and Listeria in

foods including meat and poultry products, and also, for research purpose. The Fuzzy controller designed using MATLAB program to keep a constant temperature and humidity with fast recovery in case of disturbances occurs.

An Expert Fuzzy controller to control the temperature of a heating furnace was produced [6], they replacing the conventional control strategy by the combination of both techniques, Expert and Fuzzy control which overcome the complexity of controlling the temperature of heating furnace and can give a precious control that leads to high productivity and low cost.

A Fuzzy controller with remote monitoring system for a pharmaceutical oven used for drying drugs at 80°C for 10 to 12 hours was proposed [7], the results compared with the traditional PID and showing the Fuzzy good effect.

A Fuzzy Logic Temperature Controller (FLC) for Prototypical Room was developed [8], a modeling of a prototypical room and electric heater also presented and accomplished in the SIMULINK environment of MATLAB. Fuzzy Logic Control strategy is implemented using Fuzzy Tool-box and SIMULINK facility to control the temperature of electric heater.

In this paper, a Fuzzy-PD controller is designed to control the temperature of a biomedical oven and complete heating system using the MATLAB SIMULINK environment.

\* Corresponding author: [intisar.najm@yahoo.com](mailto:intisar.najm@yahoo.com)

## 2. THE OVEN TRANSFER FUNCTION

The mathematical models of the laboratory furnace were derived based on heat transfer equations [9, 10], the applications of the plan of laboratory furnaces as with a combination of convection or radiation, as noted [4]:

Starting with the heat balance equation [11],

$$Q_{acc}(t) = Q_{in}(t) - Q_{loss}(t) \quad (1)$$

Accumulated Heat = Input Heat – Lost Heat, in (kJ)

The general form of TF equation is

$$G(S) = \frac{\text{output}}{\text{input}} \quad [12]$$

The TF of the oven represented by

$$G(S) = \frac{K}{(\tau s + 1)} e^{-\tau_d s} \quad (2)$$

Where:

K is the thermal resistance,  $\tau d$  is the time delay, and  $\tau$  is the time constant.

## 3. Fundamental Concepts of The Designed Controller

### 3.1 . PID Controller

In the interval of 1940 the PID controller was presented for robust control scheme and till now.

$K_p, K_i$  and  $K_d$  represents the PID controller parameters which can be estimated by using one of its tuning methods like trial and error or Ziegler-Nichols. It can be integrated in the forms P, I, PI, PD and PID, the equation of the PID controller can be represented as in equation (2.3) [12].

$$C_{out}(t) =$$

$$(K_p) e(t) + (K_p) \frac{1}{K_i} \int_0^t e(t) dt + (K_p) (K_d) \frac{de(t)}{dt} \quad (3)$$

Where,  $C_{out}(t)$  represent the output of the controller and  $e(t)$  the error signal.

### 3.2. Fuzzy Controller

The linguistic rule is the essential part of every Fuzzy controller, the place the discipliner assignment defined by means of the built guidelines [3]. A twain inputs certain output Fuzzy governor designed here, including a mixture related to the organic functions of triangular, trapezoidal or trigonometric inputs (MFs) or triangular output MFs.

Mamdani type fuzzy inference consists of four basic parts: input obfuscation, governmental rule, total governance, or skepticism [13], and the if-then statement is described as follows:

$$IF (e) \text{ is } A_i \text{ AND } (de) \text{ is } B_i \text{ THEN } (c) \text{ is } C \quad (4)$$

where (e and de) respectively represents the error and changes in errors represent the input FC, c is the control signal while ( $A_i, B_i$  and C) is the language variable indicated by negatives (N), positives (P), and zero (Z) in the designed controller . The FLC simplification block is shown in Fig. 1 [14].

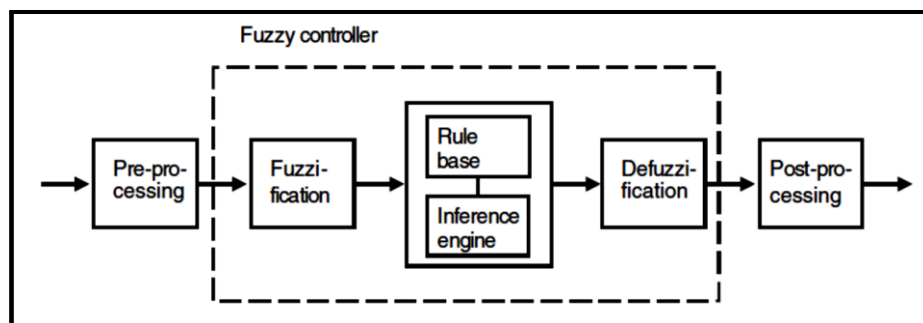

Fig. (1): Fuzzy controller building blocks

In this research, a FLC is designed with the aid of the conventional PID technique to create an efficient controller can serve the requirements of biological oven.

### 4. Simulation Results

A Fuzzy-PD controller is designed for a small oven employing for laboratory experiments and it has the ability to implement biological experiments for

cell cultures. Mathematical model for a furnace represented in first order with dead time as shown in Section 2.

TF oven, due to its two electrodes, has been experimentally determined as <sup>(15)</sup>:

$$G(s) = \frac{3.6}{(556s+1)(61s+1)}$$

The controller is designed using MATLAB SIMULINK programs. The parameters of the PD were obtained using try and error optimization method. A Mamdani-type FLC designed with two inputs, error (e) and change in error (de) and one output. It designed with three inputs and output combination of triangular and trapezoidal MFs as shown in fig. (2), fig. (3) and fig. (4) with linguistic variables (Negative, Zero, Positive) and nine rules.

The surface viewer of the FLC is also indicated in fig. (5). The heating system simulation result for the designed Fuzzy-PD controller is shown in fig. (6). The simulation results shows the high performance of the designed controller from its time specifications that represented by rise time (tr), settling time (ts), peak time (tp) and maximum peak overshoot (Mp). Where the  $M_p= 0.017$ ,  $t_r= 82.13$ ,  $t_s= 88$ , and  $t_p= 84.5$  in second.

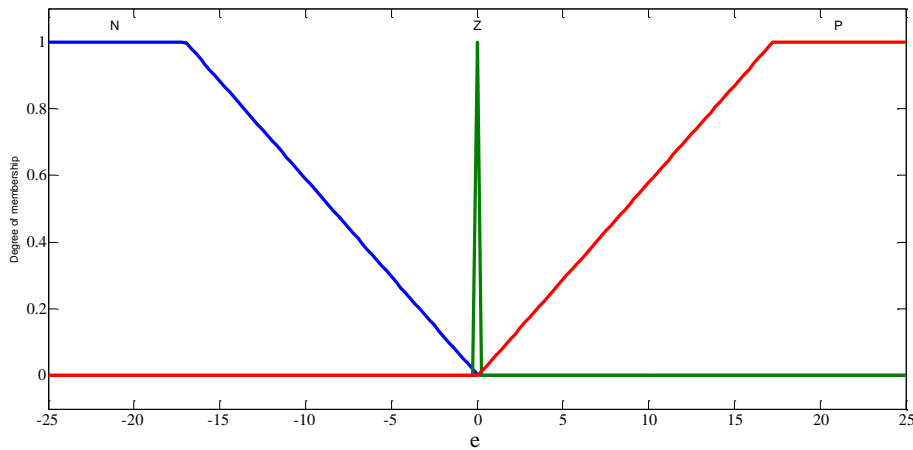

Fig. (2): FLC input error (e) MFs.

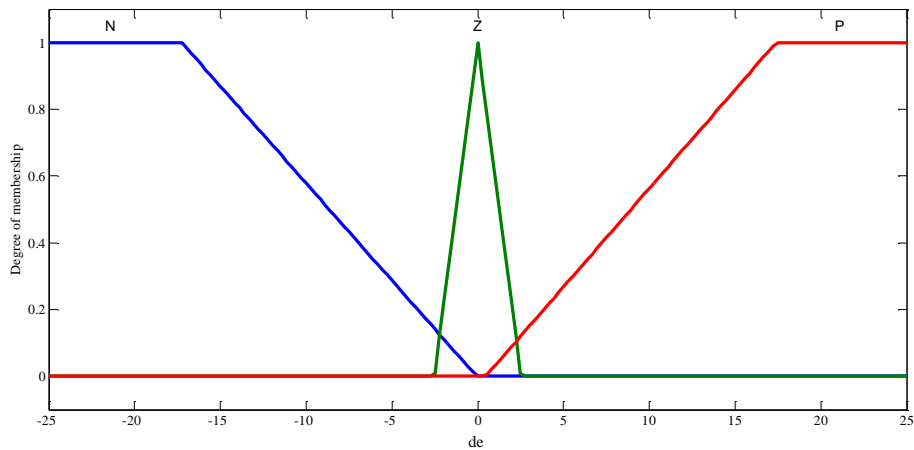

Fig.(3): FLC input change in error (de) MFs.

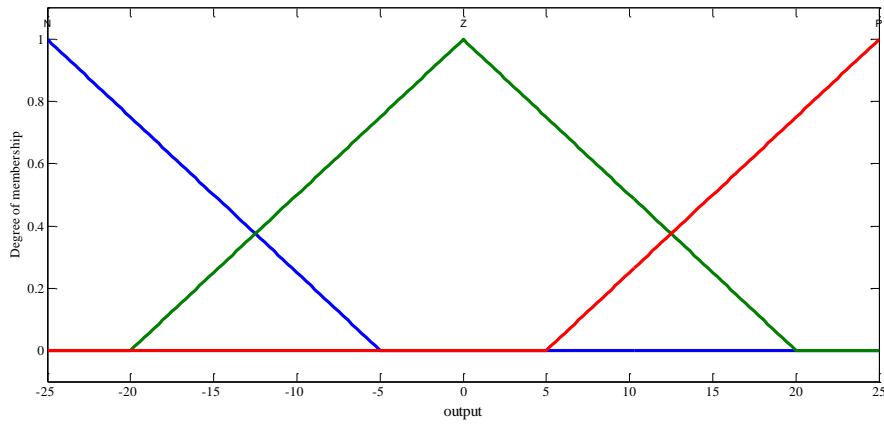

Fig.(4): FLC Output MFs.

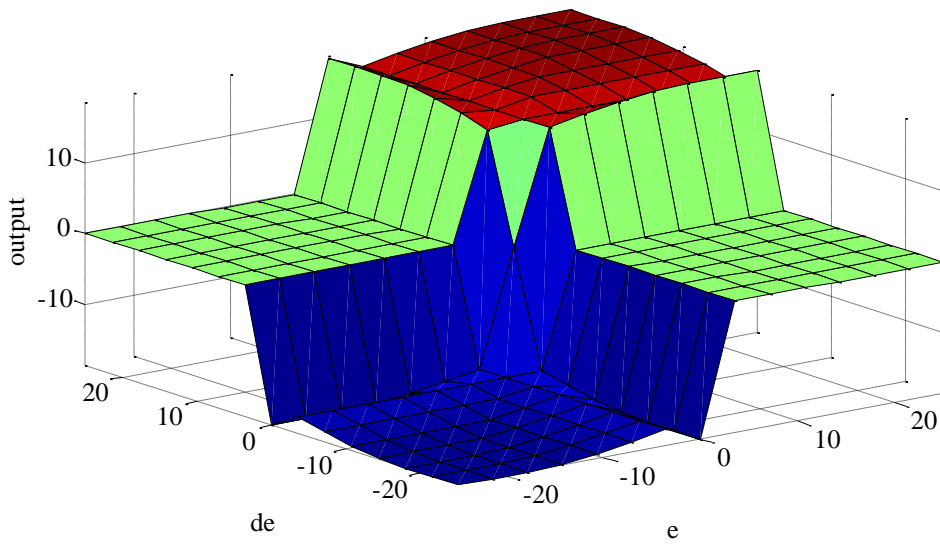

Fig. (5): FLC Surface viewer.

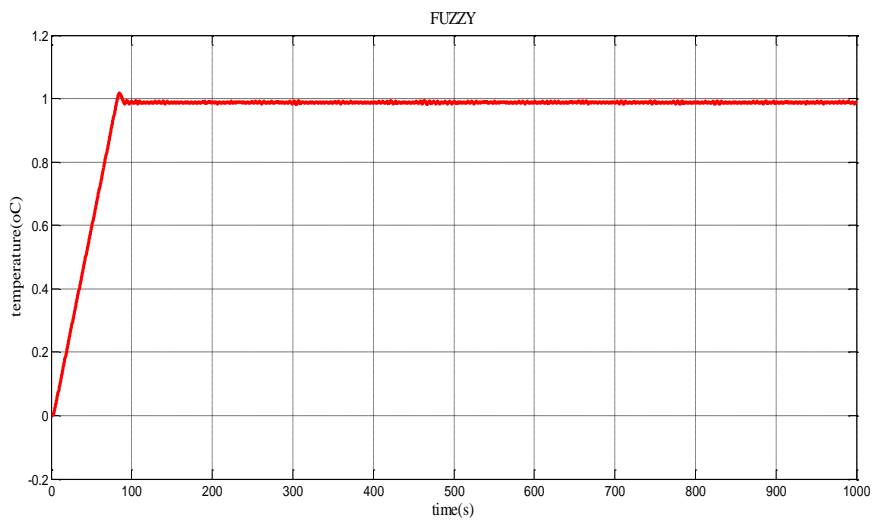

Fig.(6): The heating system response of the Fuzzy-PD controller.

## 5. Conclusions

A small laboratory oven used for medical and biological applications is used in this research. A Fuzzy-PD controller designed to control the temperature of the biological oven. The designed controller merges two techniques taking in that the advantages of the conventional PID and intelligent FLC. The surface view of the designed controller is obtained. The simulation results explain clearly the robustness of the designed Fuzzy-PD controller. The small peak overshoot, fast response and the high precision shows the good performance of the designed controller that makes it suitable for sensitive biological applications.

## 6. References

- [1]. Intisar N. and Abbas H., (2017), "Design of ANFIS Controller for Medical Oven based on FPGA", 1<sup>st</sup> edition, LAP LAMBERT Academic publishing, pp. 104.
- [2]. Likong Li Z. and Guangxiang He L., (2009), "Analysis of Heating Furnace Temperature Control System Based on Expert Fuzzy Control", IEEE International Conference on Measuring Technology and Mechatronics Automation, pp. 542-545.
- [3]. Wei J., (2010), "Research on the Temperature Control System Based on Fuzzy Self-Tuning PID", IEEE International Conference on Computer Design and Applications, Vol. 3, pp. 13-15.
- [4]. Abbas H. and Intisar N., (2016), "Medical Oven Temperature Control Based On Soft Computing Techniques", Diyala Journal of Engineering Sciences, Vol. 09, No. 03, pp. 71-80.
- [5]. Harbour W. D. and Martin T. W., (2006), "Development of a Fuzzy Logic Control System in MATLAB for an Air Impingement Oven", IEEE, pp. 319-324.
- [6]. Liu Z., Li L., Wen L. and He G., (2009), "Analysis of Heating Furnace Temperature Control System Based on Expert Fuzzy Control", IEEE International Conference on Measuring Technology and Mechatronics Automation, pp. 542-545.
- [7]. Wei-zhao Z., Sheng-qian M., Man-hong F. and Jin-long L., (2010), "Design of Temperature and Humidity Intelligent Monitoring System", IEEE International Conference on Electrical and Control Engineering, pp. 782-785.
- [8]. Patil C.B., (2016), "Thermal Modeling and Fuzzy Logic Temperature Controller for Prototypical Room", International Journal of Engineering Trends and Technology (IJETT), Vol. 36, No. 8, pp.432-438.
- [9]. Holman J. P., (2010), "Heat Transfer", Tenth edition, Americas, New York, McGraw-Hill, pp. 725.
- [10]. Cengel Y. A., (2002), "Heat Transfer A Practical Approach", Second edition, pp. 853.
- [11]. Al-Araji A. S., (2014), "Applying Cognitive Methodology in Designing On-Line Auto-Tuning Robust PID Controller for the Real Heating System", Journal of Engineering, Vol. 20, No. 9, pp. 43-61.
- [12]. Ogata K., (2010), "Modern Control Engineering", Fifth edition, One Lake Street, Upper Saddle River, New Jersey, Prentice Hall, pp. 894.
- [13]. Negnevitsky M., (2005), "Artificial Intelligence A guide to Intelligent Systems", Second edition, Britain, Addison-Wesley, pp. 415.
- [14]. Jan Jantzen, (2007), "Foundations of Fuzzy Control", John Wiley and Sons, Ltd.
- [15]. Ribeiro T. R., Augusto J. S., (2010), Ibersensor Lisbon Portugal.